

R33	R36:	
LPC1343		0R
LPC1114		0R
LPC1111X		0R
LPC11C12_14		DNP

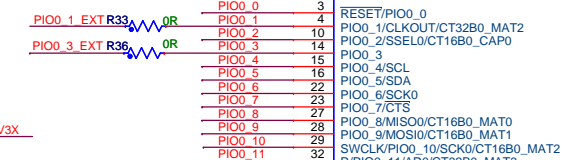

PIO0_0	3	RESET/PIO_0
PIO0_1	4	PIO0_1/CLKOUT/CT32B0_MAT2
PIO0_2	10	PIO0_2/SSEL0/CT16B0_CAP0
PIO0_3	14	PIO0_3
PIO0_4	15	PIO0_4
PIO0_5	16	PIO0_4/SCL
PIO0_6	22	PIO0_5/SDA
PIO0_7	23	PIO0_6/SCK0
PIO0_8	27	PIO0_7/CTS
PIO0_9	28	PIO0_8/MISO0/CT16B0_MAT0
PIO0_10	29	PIO0_9/MOSI0/CT16B0_MAT1
PIO0_11	32	SWCLK/PIO0_10/SCK0/CT16B0_MAT2
		R/PIO0_11/AD0/CT32B0_MAT3
PIO1_0	33	R/PIO1_0/AD1/CT32B1_CAP0
PIO1_1	34	R/PIO1_1/AD2/CT32B1_MAT0
PIO1_2	35	R/PIO1_2/AD3/CT32B1_MAT1
PIO1_3	39	SWDIO/PIO1_3/AD4/CT32B1_MAT2
PIO1_4	40	PIO1_4
PIO1_5	45	PIO1_4/AD5/CT32B1_MAT3/WAKEUP
PIO1_6	46	PIO1_5/RTS/CT32B0_CAP0
PIO1_7	47	PIO1_6/RXD/CT32B0_MAT0
PIO1_8	9	PIO1_7/TXD/CT32B0_MAT1
PIO1_9	17	PIO1_8/CT16B1_CAP0
PIO1_10	30	PIO1_9/CT16B1_MAT0
PIO1_11	42	PIO1_10/AD6/CT16B1_MAT1
		PIO1_11/AD7
PIO2_0	2	PIO2_0/DTR/SSEL1
PIO2_1	13	PIO2_1/DSR/SCK1
PIO2_2	25	PIO2_2/DCC/MISO1
PIO2_3	38	PIO2_3/R/MOSI1
	19	CAN_RXD
	20	CAN_TXD
PIO2_6	1	PIO2_6
PIO2_7	11	PIO2_7
PIO2_8	12	PIO2_8
PIO2_9	34	PIO2_9
PIO2_10	25	PIO2_10
PIO2_11	31	PIO2_11/SCK0
PIO3_0	36	PIO3_0/DTR
PIO3_1	37	PIO3_1/DSR
PIO3_2	43	PIO3_2/DCC
PIO3_3	48	PIO3_3/R

R38	R39:	
LPC1343		39R
LPC1114		39R
LPC1111X		0R
LPC11AX		0R
LPC11C12_14		DNP

R40	R41:	
LPC1343		DNP
LPC1114		DNP
LPC1111X		DNP
LPC11AX		DNP
LPC11C12_14		0R

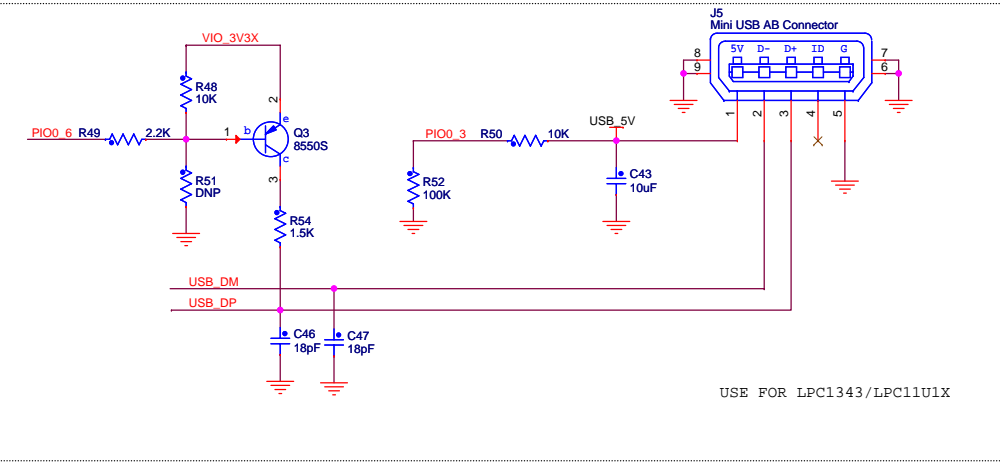
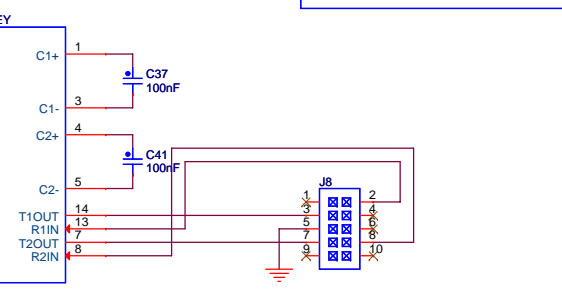
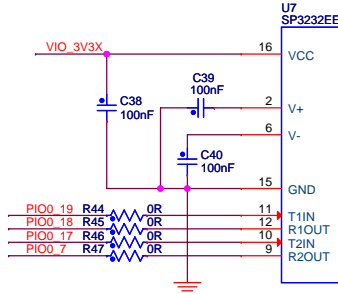
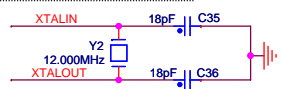
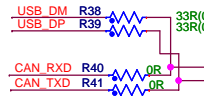

USE FOR LPC1343/LPC1111X

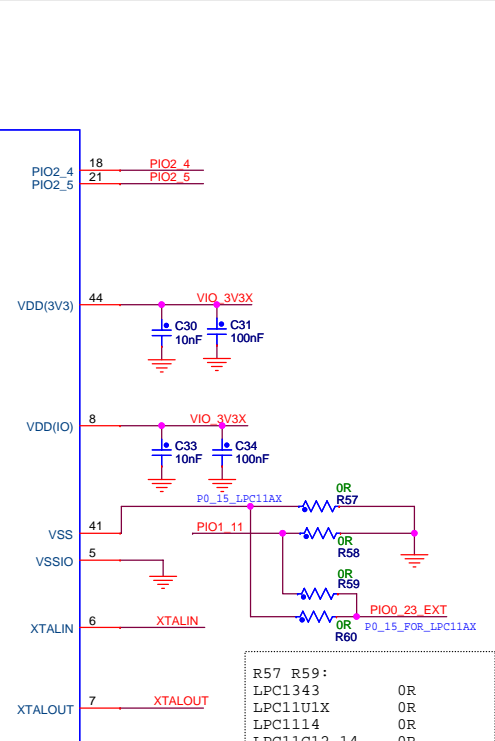

R57	R59:	
LPC1343		0R
LPC1111X		0R
LPC1114		0R
LPC11C12_14		0R
LPC11AX		DNP

R58	R60:	
LPC1343		DNP
LPC1111X		DNP
LPC1114		DNP
LPC11C12_14		DNP
LPC11AX		0R

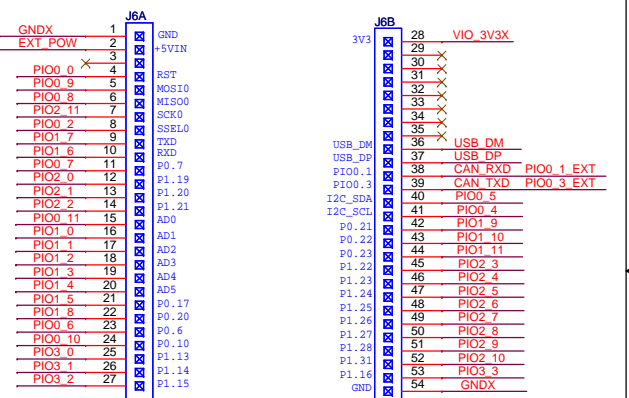
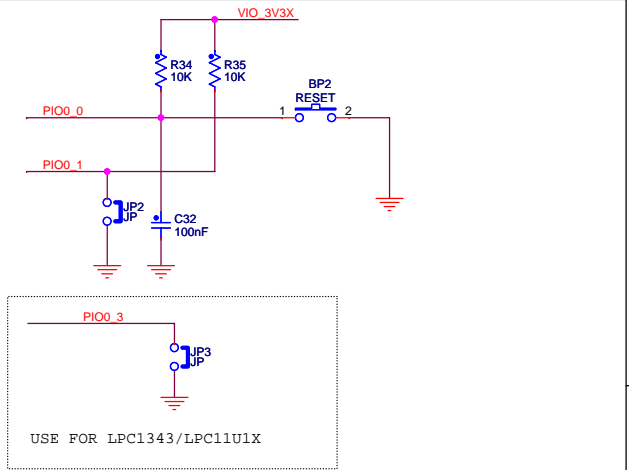
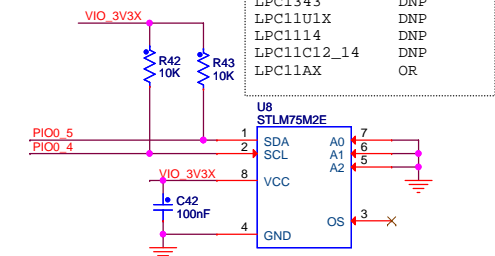

27Pin_2.54MM

27Pin_2.54MM

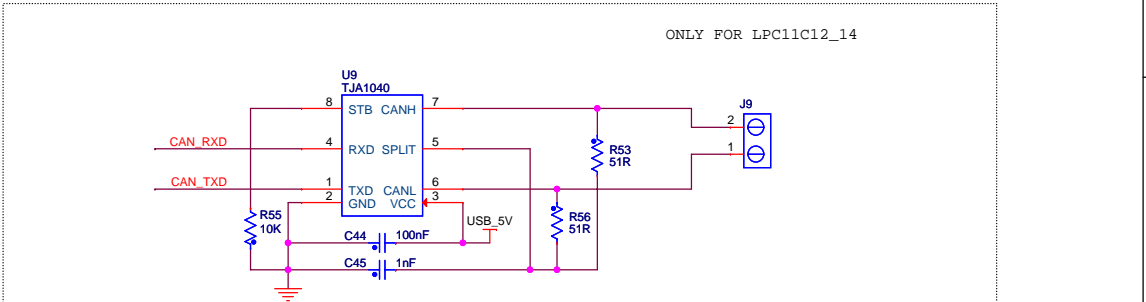

ONLY FOR LPC11C12_14

CooCox <http://www.coocox.org/>

Title: **LPC11C14**

Size: A3	Document Number: LPC11C14	Rev: A
Draw By:	Date: Tuesday, November 08, 2011	Sheet: 2 of 2